

COMPACT EXTRACTOR



MANUAL SHAKER

STUDIED FOR SHAVINGS, GRANULES AND WET MATERIALS •
HAND SHAKER SYSTEM FOR STAR FILTER CLEANING •



SIMPLE AND EFFICIENT

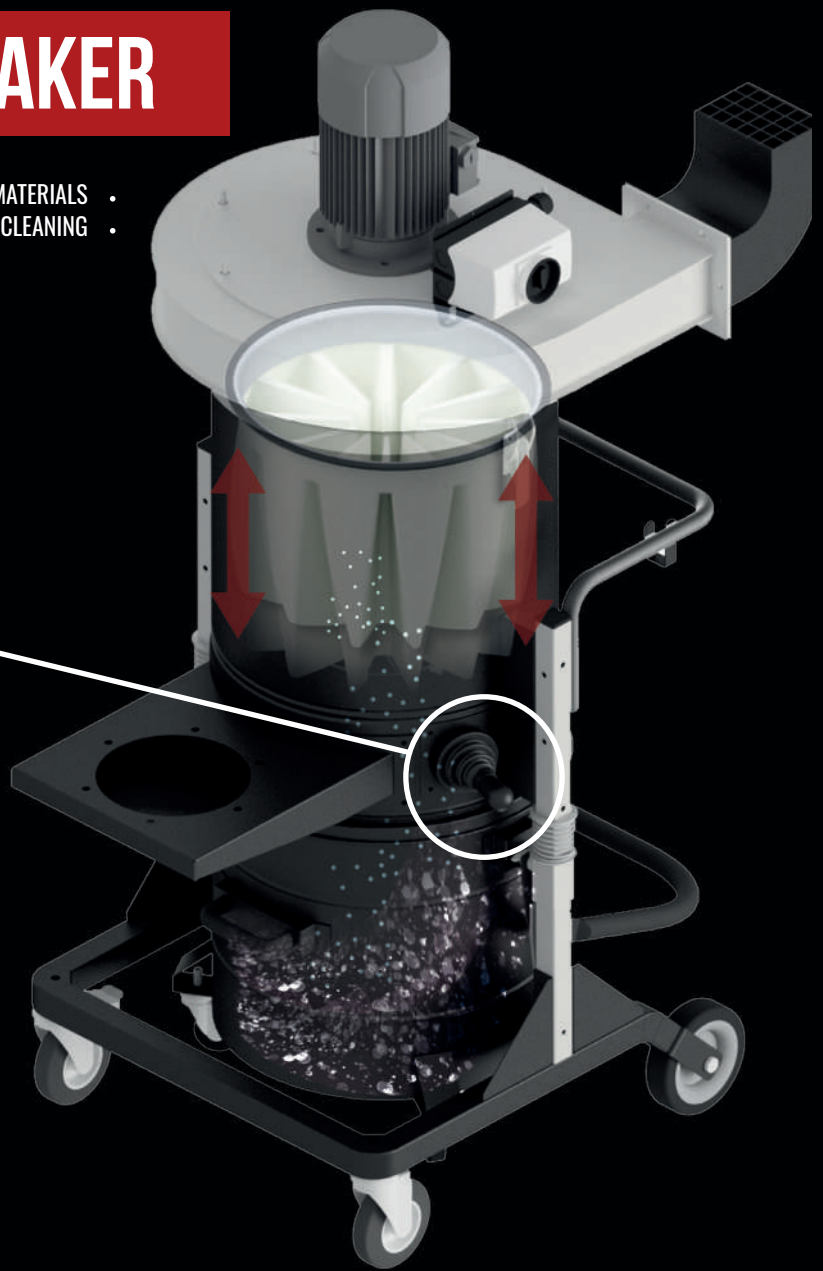

PSC SYSTEM

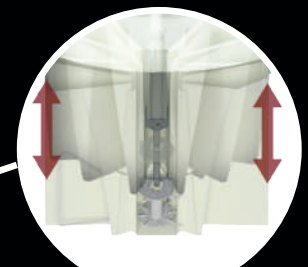

EFFICIENT AND RELIABLE

STUDIED FOR SHAVINGS, GRANULES AND WET MATERIALS •
SEMI - AUTOMATIC HAND SHAKER SYSTEM FOR STAR FILTER CLEANING •

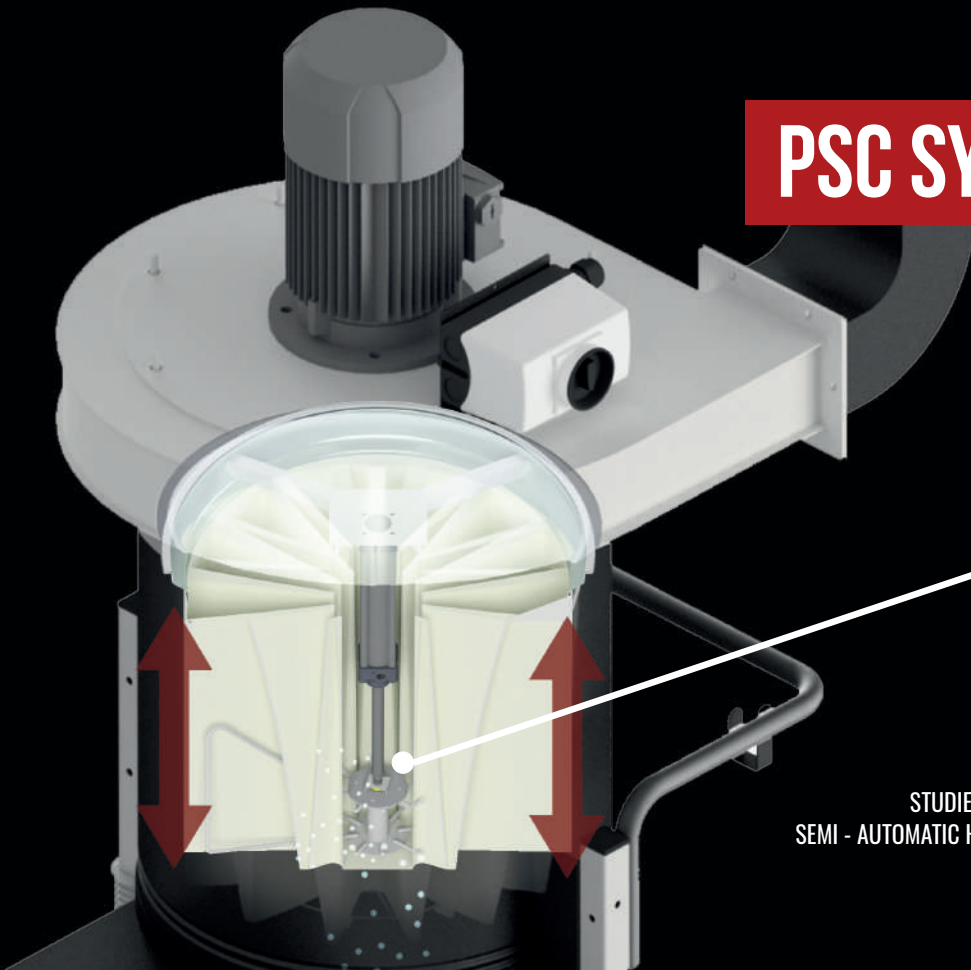

SP-SYSTEM

CLEANING
THE FILTER
IS IMPORTANT

THE SP SYSTEM ALLOWS TO KEEP THE FILTER CLEAN AUTOMATICALLY WITHOUT STOPPING THE VACUUM. EACH FILTER IS CLEANED PERIODICALLY WITH A COMPRESSED AIR JET.

THE SP SYSTEM IS PERFECT FOR LARGE QUANTITIES OF FINE AND DIFFICULT DUSTS.

CYCLICAL PROGRAMMER INSTALLED ON THE VACUUM THANKS TO THE TOUCHSCREEN IT IS POSSIBLE TO SET THE CLEANING CYCLE AND ADJUST THE SYSTEM ACCORDING TO THE QUANTITY AND THE KIND OF POWER.

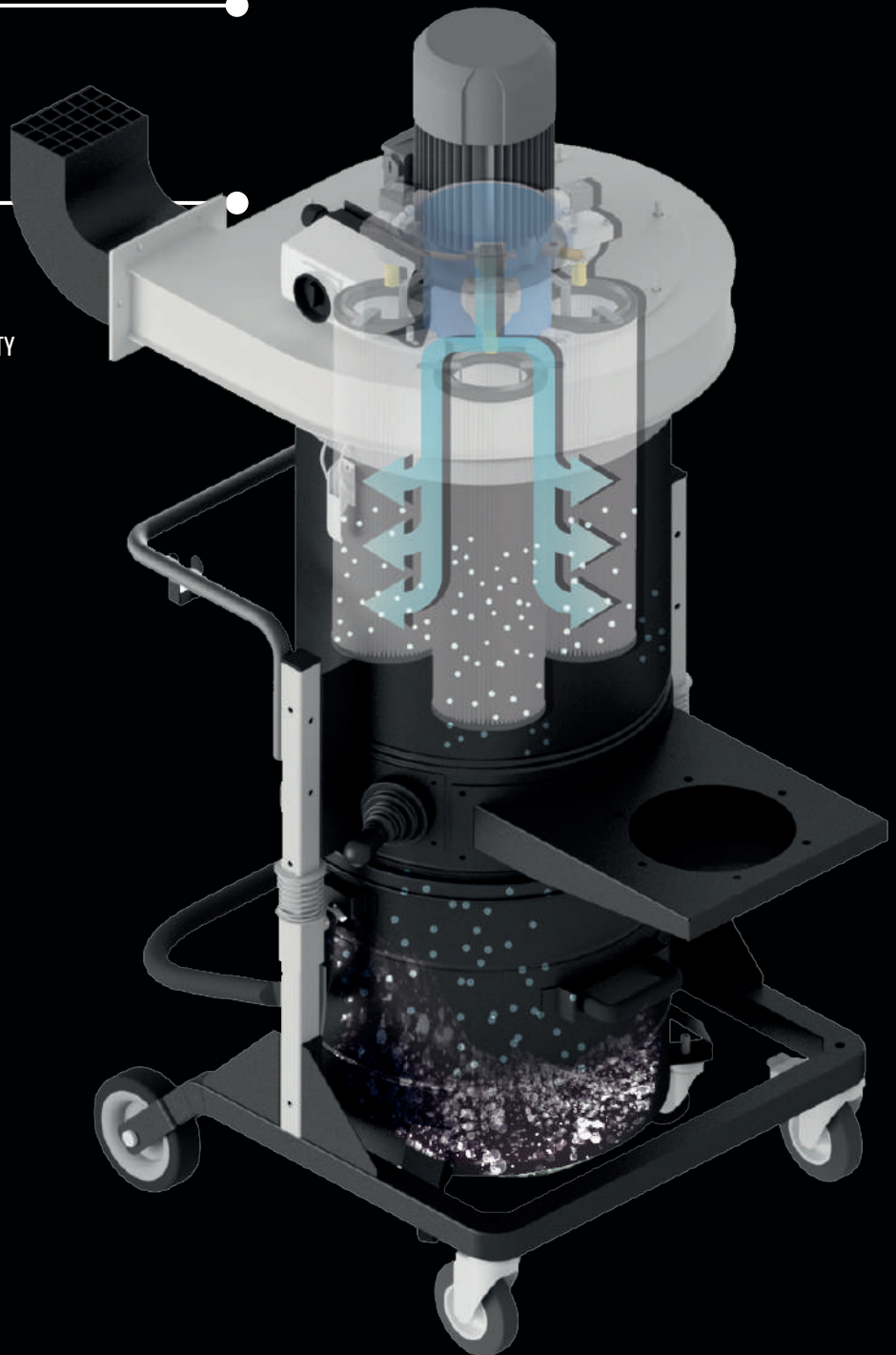

DF075

DF075



POWER	HP	1.5
VOLTAGE FREQUENCY	V Hz	480 60
MAXIMUM VACUUM	inH2O	9.84 9.25 5.51
AVAILABLE STATIC INLET PRESSURE	inH2O	9.84 8.66 3.93
MAXIMUM AIR FLOW	CFM	264 547 883
INLET	Ø in	2.76 3.94 4.72
SURFACE AREA	in²	3720
FILTRATION EFFICIENCY		CLASSE EN 60335-2-69 - M CLASS (1µ)
BIN CAPACITY	gal	17 / 26

STANDARD M CLASS STAR FILTER SUITABLE FOR ALL NEEDS



ANTISTATIC
"M" CLASS
STAR FILTER



NOMEX



PTFE



PTFE
ANTISTATIC



PSC

SEMI-AUTOMATIC
PNEUMATIC
FILTER SHAKER



SP SYSTEM

AUTOMATIC
REVERSE
JET CLEANING
SYSTEM

DF22



POWER	HP	3.45
VOLTAGE FREQUENCY	V Hz	480 60
MAXIMUM VACUUM	inH2O	14.2 14.9 14.2
AVAILABLE STATIC INLET PRESSURE	inH2O	14.2 14.5 13.7
MAXIMUM AIR FLOW	CFM	265 589 753
INLET	Ø in	3.94 4.72 5.90
SURFACE AREA	in ²	3720
FILTRATION EFFICIENCY		CLASSE EN 60335-2-69 - M CLASS (1µ)
BIN CAPACITY	gal	17 / 26



**ABSOLUTE FILTER
HEPA H14**

FILTRATION EFFICIENCY
OF 99,995 % OVER 0,18 µ



3 YEARS

WARRANTY

ORDER ALL REPLACEMENT FILTERS ALONG WITH THE VACUUM CLEANER
GET THE **DEAL** OF AN **EXTENDED WARRANTY**

DF40



POWER	HP	6.2
VOLTAGE FREQUENCY	V Hz	480 60
MAXIMUM VACUUM	inH2O	18.5 15.7 10.6
AVAILABLE STATIC INLET PRESSURE	inH2O	18.1 13.7 7.8
MAXIMUM AIR FLOW	CFM	589 1295 1883
INLET	Ø in	5.90 7.09 7.87
SURFACE AREA	in²	6975
FILTRATION EFFICIENCY		CLASSE EN 60335-2-69 - M CLASS (1µ)
BIN CAPACITY	gal	17

STANDARD M CLASS STAR FILTER SUITABLE FOR ALL NEEDS



ANTISTATIC
"M" CLASS
STAR FILTER



NOMEX



PTFE



PTFE
ANTISTATIC



PSC

SEMI-AUTOMATIC
PNEUMATIC
FILTER SHAKER



SP SYSTEM

AUTOMATIC
REVERSE
JET CLEANING
SYSTEM

DF FIX



		DF FIX 55	DF FIX 75
POWER	HP	8.5	9
VOLTAGE FREQUENCY	V Hz	480 / 60	480 / 60
MAXIMUM VACUUM	inH2O	25.9	39.7
AVAILABLE STATIC INLET PRESSURE	inH2O	25.2	21.2
MAXIMUM AIR FLOW	CFM	1589	2472
INLET	Ø in	7.87	7.87
SURFACE AREA	in ²	6975	6975
FILTRATION EFFICIENCY		CLASSE EN 60335-2-69 - M CLASS (1µ)	CLASSE EN 60335-2-69 - M CLASS (1µ)
BIN CAPACITY	gal	46	46



**ABSOLUTE FILTER
HEPA H14**

FILTRATION EFFICIENCY
OF 99,995 % OVER 0,18 µ



3 YEARS

WARRANTY

ORDER ALL REPLACEMENT FILTERS ALONG WITH THE VACUUM CLEANER
GET THE **DEAL** OF AN **EXTENDED WARRANTY**

DISCHARGE SYSTEMS



BALANCED
FLAP

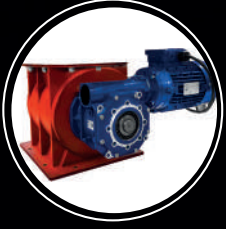

DISCHARGE
SYSTEMS



MANUAL
DISCHARGE
BUTTERFLY VALVE



DOUBLE
ELECTRO
PNEUMATIC
DISCHARGING
BUTTERFLY VALVE



ROTATING
LEVEL SENSOR



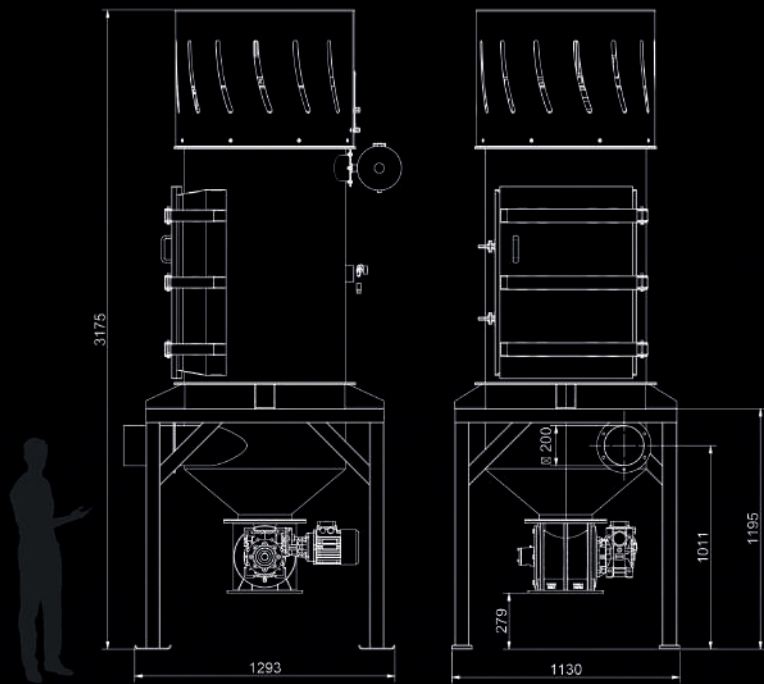

DV-AIR FLOW

DV-AIR AF 40

DV-AIR AF 55

		DV-AIR AF 40	DV-AIR AF 55
POWER	HP	6,2	8,5
VOLTAGE FREQUENCY	V Hz	480 60	480 60
MAXIMUM VACUUM	in	18.5	25.9
AVAILABLE STATIC INLET PRESSURE	in	18.1	25.2
MAXIMUM AIR FLOW	CFM	1295	1589
INLET	Ø in	7.87	7.87
SURFACE AREA	in ²	52700	52700
FILTRATION EFFICIENCY		CLASSE EN 60335-2-69 - M CLASS (1µ)	CLASSE EN 60335-2-69 - M CLASS (1µ)



SP SYSTEM

AUTOMATIC
REVERSE JET CLEANING
SYSTEM



3 YEARS
WARRANTY

ORDER ALL REPLACEMENT FILTERS ALONG WITH THE VACUUM CLEANER
GET THE DEAL OF AN EXTENDED WARRANTY

FILTER SOLUTIONS

TYPE OF FILTERS

"M" CLASS STAR FILTER



FINE DUSTS, GRANULES, SHAVINGS AND DRY MATERIALS

ANTISTATIC "M" CLASS STAR FILTER



FINE DUSTS, GRANULES, SHAVINGS AND MATERIALS TENDING TO BE ELECTROSTATICALLY CHARGED. STANDARD ON ALL ATEX MODELS

NOMEX STAR FILTER



DUSTS AND SOLIDS WITH TEMPERATURES UNTIL 250°C

ACTIVATED CARBON FILTER



8KG ACTIVATED CARBON ELIMINATES BAD SMELLS

PTFE STAR FILTER



VERY FINE AND CLOGGING DUSTS, HYGROSCOPIC AND WET MATERIALS, CERTIFIED FOR FOOD

M CLASS CARTRIDGE

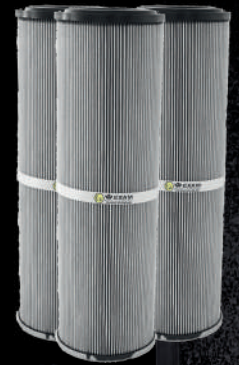

LARGE QUANTITIES OF FINE AND CLOGGING DUSTS, AVAILABLE ON ALL SP VERSIONS, AUTOMATIC REVERSE JET CLEANING



FILTRATION EFFICIENCY OF 99,995 % OVER 0,18 µ

SUCTION ARMS

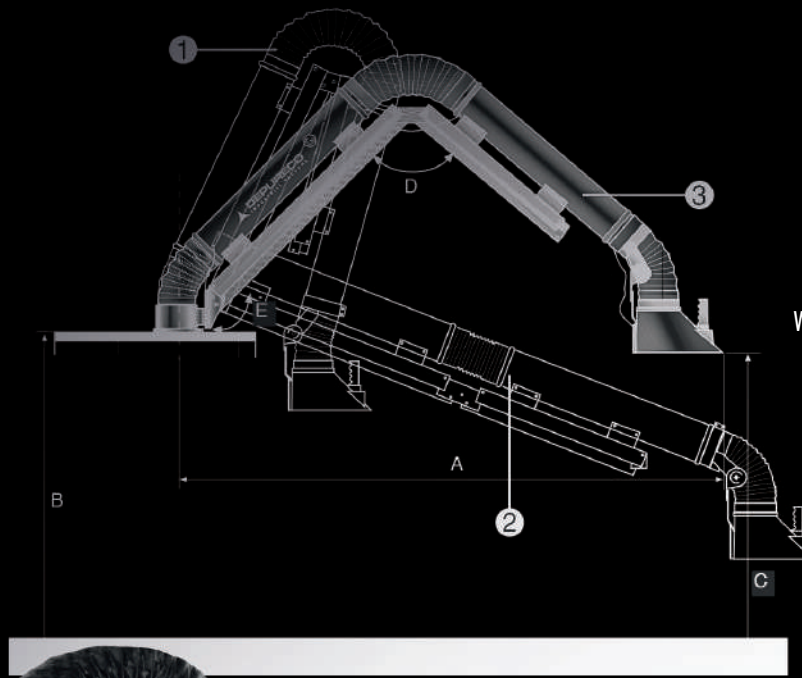

TROLLEY VERSION

CLOSED ARM 1
25 IN

OPEN ARM 2
102 IN

WORKING POSITION 3
90.5 IN

TYPE OF ARMS

ARTICULATED ARM
L = 12 06 IN

CE  II 2 G/D

ARTICULATED ARM
L = 12 06 IN





#USTOBEGLEAN

DEPURECO INDUSTRIAL VACUUMS USA

19121 MARKETPLACE AVENUE, BUILDING 1, SUITE 165
PLUM CREEK BUSINESS PARK - KYLE, TEXAS 78640
+1 737 70 44 347
INFO@DEPURECOUSA.COM - WWW.DEPURECOUSA.COM

 @DEPURECOINDUSTRIALVACUUMS

 @DEPURECO INDUSTRIAL VACUUMS

