

M100 TAN LP H



Depureco Industrial Vacuums USA

19121 Marketplace Avenue, Building 1, Suite 165
Plum Creek Business Park • Kyle • TX 78640

www.depurecousa.com
info@depurecousa.com

3,3 HP
POWER

3.720 in²
FILTER

Longopac
CAPACITY



3 POWERFUL BY-PASS MOTORS
110V | 60 Hz
Max Airflow= 336 CFM
Max Depression= 98 inH2O



STANDARD H 14 HEPA FILTER



4340 in²

STANDARD M CLASS FILTER



Filter surface
3.720 in²



OPTIONAL MTF FILTER



Filter surface
3.720 in²



MANUAL FILTER CLEANING SYSTEM

Easily clean the filter with an ergonomic system.

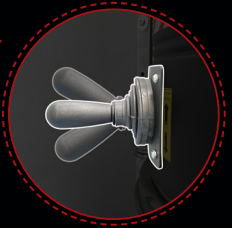

CYCLONIC SYSTEM

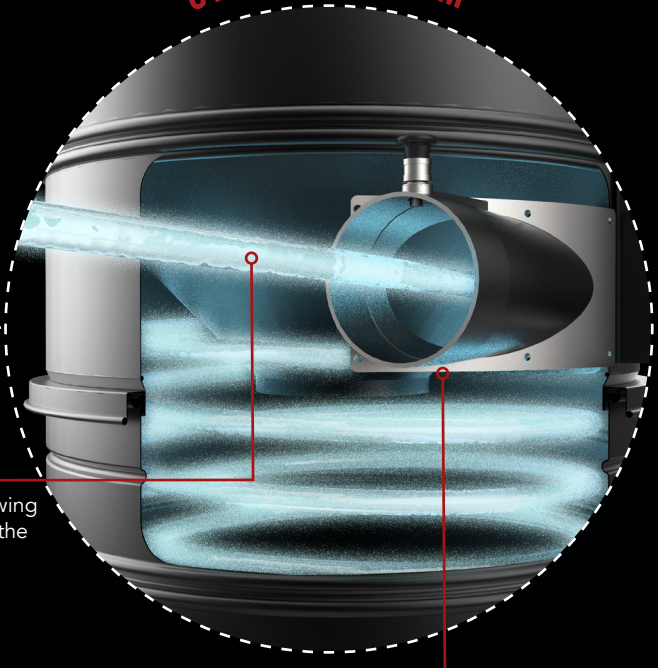

CYCLON FOR FILTER PROTECTION

The metal cyclone helps slowing down the dust and protects the filter

EFFICIENT CYCLONIC EFFECT

The dust, entering the vacuum, experiences a cyclonic effect that slows down the powder making it fall into the Longopac® bagging system.

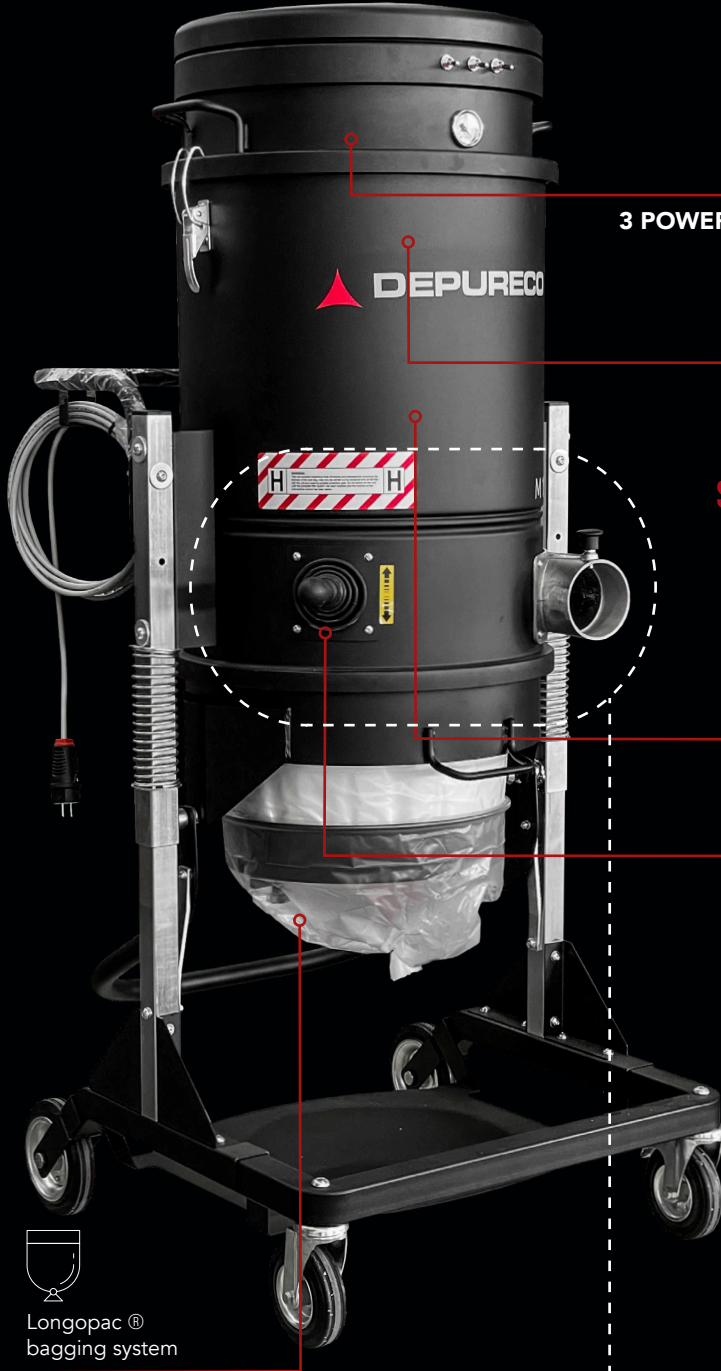

Longopac®
bagging system

HIGHLY TRANSPORTABLE

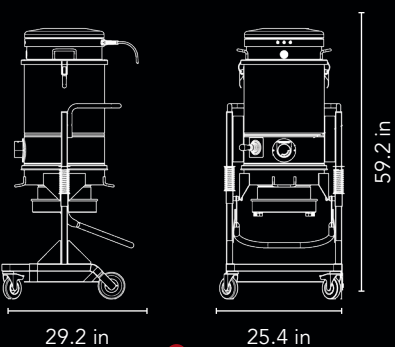

Weight: 154 lbs

SPEC SHEET

	Units	M 100 TAN LPH
Motors Type		3 - By-Pass
Power	HP	3,3
Voltage Frequency	V Hz	120/60
Maximum vacuum	inH2O	98
Maximum air flow	CFM	336
Inlet	Ø in	2,75
Noise level - (EN ISO 3744)	dB(A)	72
Bin capacity	gal	Longopac®
Dimensions	in	25.98 X 31.50
Height	in	59.65
Weight	lb	154
Primary filter		
Type		Star filter
Surface area Diameter	in ² in	3.800
(Class EN 60335-2-69)		M Class
Media		Antistatic polyester
Filter cleaning		Manual shaker
Absolute filter		
Surface area	in ²	4.340
(Class - EN 1822)		H14
Media		Fiberglass

OPTIONAL FILTERS



BFL
M class filter 409028,6 ft²

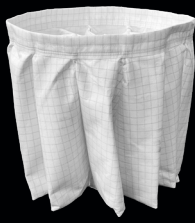

ANT M
Antistatic filter



MTF
Teflon filter



NOMEX
482° F Resistant filter



PTFE
PTFE filter 409028,6 ft²

OPTIONAL



AB
Accessory basket



GRD
Grounding



TAN
Tangential inlet + cyclone

ACCESSORIES



Iron reducer 2,75/1,96 in
P10866



Wet & Dry kit 1,96 in
P11887



Starter kit 1,96 in
P12350