



RAM OIL 280 MP



Depureco Industrial Vacuums USA

19121 Marketplace Avenue, Building 1, Suite 165
Plum Creek Business Park • Kyle • TX 78640

www.depurecousa.com
info@depurecousa.com

-  Power: 3.3 HP
-  Liquid capacity: 74 gal
Solid capacity: 11 gal
-  Sucking time: 74 gal/min
Dumping time: 74 gal/min

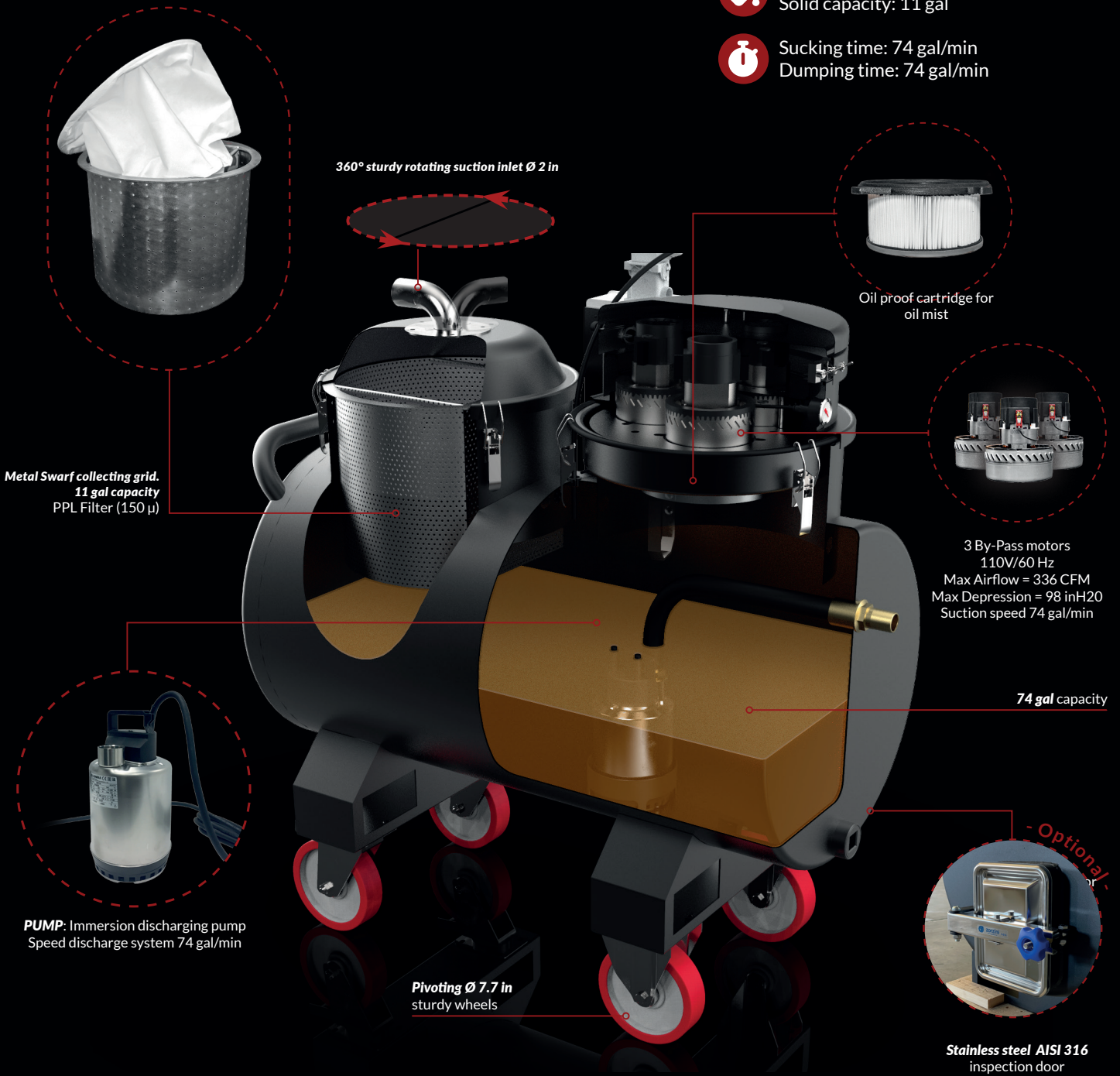

HIGHLY TRANSPORTABLE

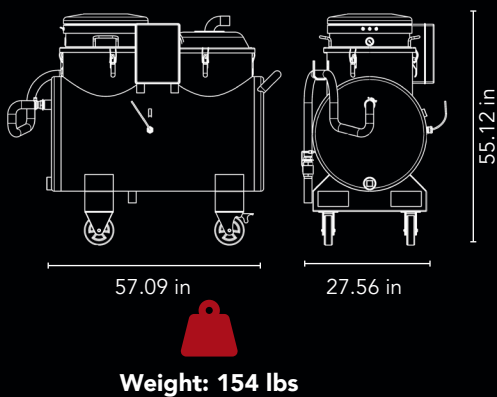

COMPACT AND EASY TO HANDLE

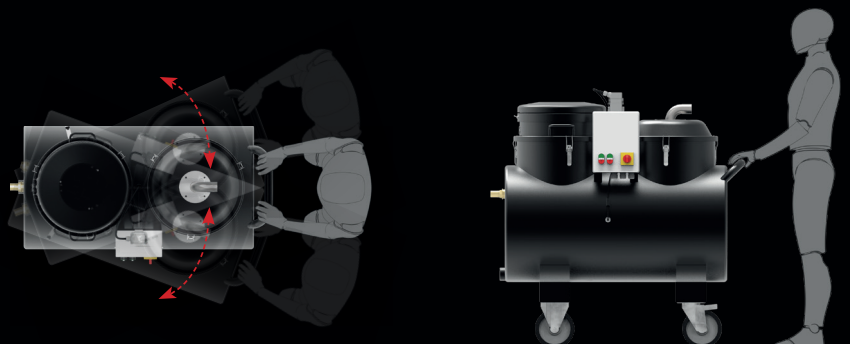

SPEC SHEET

	Units	RAM OIL 280 MP
Motors Type		3 - By-Pass
Power	HP	3.3
Voltage Frequency	V/Hz	110/60
Maximum vacuum	inH2O	98
Maximum air flow	CFM	336
Inlet	Ø in	2
Noise level - (EN ISO 3744)	dB(A)	72
Liquid capacity	gal	74
Solid capacity	gal	11
Dimensions	in	27.56 x 57.09
Height	In	55.12
Weight	lb	485
Suction time	gal/min	74
Dumping time	gal/min	74
Discharge system		
Type		Immersion pump
Power	HP	1
Voltage/Frequency	V/Hz	110/60

INCLUDED



**PPL disposal filter 150
µ efficiency**



TNT filter



Oil & swarf KIT

ACCESSORIES

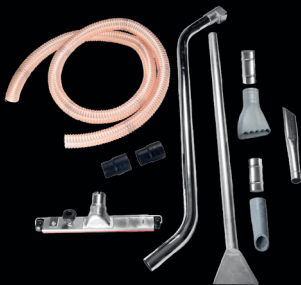

Oil & swarf KIT PRO