

# COMPANY PROFILE



OUR MISSION

**BUILDING  
THE BEST  
INDUSTRIAL  
VACUUMS.  
WITH NO  
COMPROMISE.**



# EVERY VACUUM IS DESIGNED WITH CUSTOMER IN MIND

23

21

Every product is designed with the aim of providing the best vacuuming solution to the customer application requirements in terms of performance,

safety and usability. Our 50 year experience in vacuum solutions allows us to design, build and deliver state-of-the-art products in a fast and reliable way.

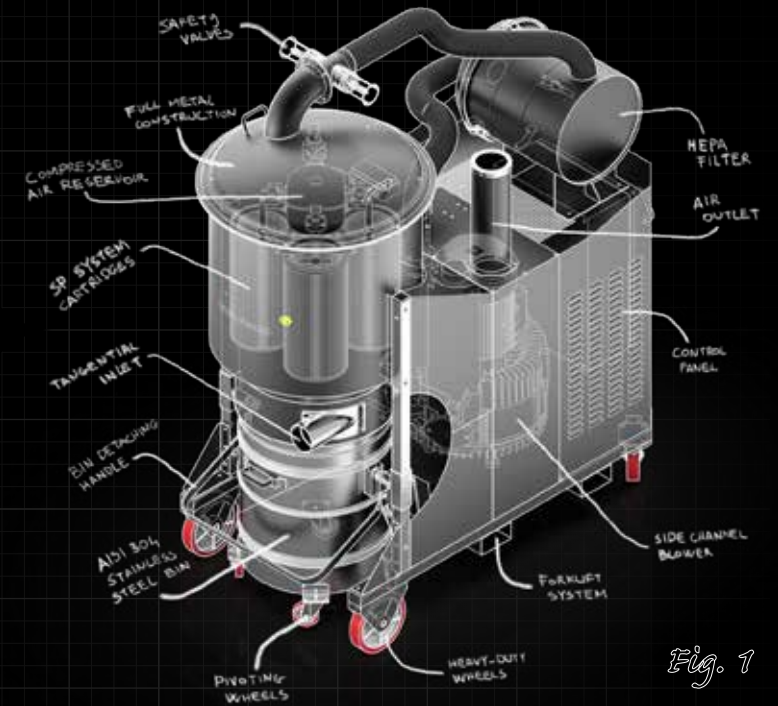

Fig. 1

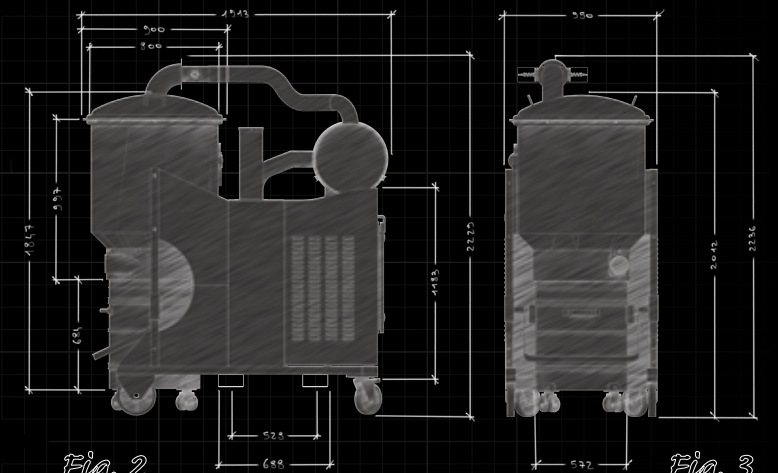

Fig. 2

Fig. 3



# WE BUILD OUR VACUUMS

TEAM  
OF EXPERTS IN  
VACUUM SOLUTIONS



COMPREHENSIVE  
PRODUCTION  
FACILITY



Everything is built in-house at Depureco. Our team of experts pay continuous attention to every single detail, in order to create products able to perform even in the harshest working conditions, exceeding

customer expectations. Our large stock parts bring an extraordinary flexibility in production, making possible to quickly and effectively answer to any customer need.



# 100% FUNCTIONAL TESTING ON EVERY VACUUM



We strongly believe that the main feature of production equipment is reliability. That's why quality check is everything to us! We run complete functional testing of every product

before shipment, in order to provide the customer with a durable, reliable and safe product that will help its production and will last a lifetime.

# ONLY THE BEST!

**BEST QUALITY  
SIDE CHANNEL  
BLOWERS**



**BEST QUALITY  
COMPONENTS**



**BEST QUALITY  
MATERIALS**



Powder coated metal



Stainless steel  
AISI 304 & 316



Sturdy poliester

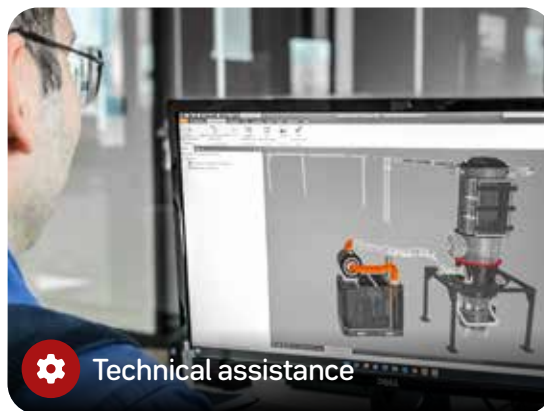

 Technical assistance



 Sales and Marketing support



 Customer Service

## HUGE STOCK READY FOR PROMPT DELIVERY

At Depureco USA, we take pride in our extensive inventory of over 100 high-quality vacuums and a wide range of accessories and spare parts, all readily available for prompt delivery.

# WHY BECOME A DEPURECO PARTNER?



## 3 YEARS WARRANTY

Depureco is the only manufacturer offering up to 3 years warranty on its products.



## HUGE STOCK FOR PROMPT DELIVERY

Our extensive selection comprises more than 100 vacuum models along with a diverse array of accessories and spare parts, ensuring we can promptly deliver everything you need.



## TRAINING FOR THE DEALER

Depureco dealers are part of a unique network, getting comprehensive training to better understand the industrial vacuum world and the opportunity it represents to generate business.



## WORLDWIDE RECOGNITION

Depureco is an international brand that sells its products worldwide since more than 50 years and is renowned for as one of the most important brands on the market.



## SAFETY AS #1 PRIORITY

Safety, quality and excellence are a must-have for every Depureco product. We invested in a wide range of safety and quality certifications in order to assure maximum reliability at the customer.



## PRIVATE LABEL

With our private label service, we ensure that every detail is tailored to your brand's vision, allowing you to deliver a truly unique and personalized experience to your customers.



## DROP SHIPPING

We understand the significance of timely deliveries. That's why we provide a convenient dropshipping service.



## MORE THAN CUSTOMERS

We believe in building long-lasting relationships and trust. No matter the problem, we will always be there with you to find the solution together.



# CERTIFIED QUALITY



Our products meet EU safety, health and environmental requirements



Our production processes follow the ISO9001 quality management system criteria



We produce a wide range of vacuum cleaners certified for use in Atex zones 1, 2, 21, 22



Our range includes products compliant to NFPA regulation

## OUR COMMITMENT

Taking care of people also means **protecting and preserving the planet** we live on. And this does not just imply guaranteeing a clean and healthy workplace, but also being proactive with tangible

actions to contribute to the planet's wellbeing and ensure a greener future for generations to come. With our **responsible reforestation** and tree-planting project, carried out in **partnership**

**with Tree Nation**, for each vacuum cleaner sold we plant a tree, thereby offsetting the CO2 we produce. Because trees are the Earth's real vacuum cleaners.



Scan the QR-Code to view our **Depureco Forest**



## DEPURECO CARES ABOUT OUR PLANET



PHARMACEUTICAL  
INDUSTRY



COFFE, TEA AND  
TOBACCO



ELECTRONIC  
INDUSTRY



TEXTILE INDUSTRY



BRICKS AND TILES  
PRODUCTION



WIND TURBINES  
SANDING



FEED MILLS



ATEX



CONSTRUCTION



AUTOMOTIVE



ASBESTOS



WELDING FUMES



OIL & SWARF



CNC CUTTING  
TABLES



SHIPYARDS

# TONS OF OPPORTUNITIES!



ALLUMINIUM AND  
PVC CUTTING



CEMENT PLANTS



HIGH  
TEMPERATURES



PAPER MILLS



MILLS



FOOD INDUSTRY



CHEMICAL  
INDUSTRY



RUBBER INDUSTRY



PACKAGING  
MACHINES



SURFACE  
PREPARATION



WOOD INDUSTRY



SHOT AND  
SAND BLASTING



ADDITIVE  
MANUFACTURING



INDUSTRIAL  
PAINTING



LEATHER



MILITARY



METAL WORKING



SHOOTING RANGES



AIR FORCE



FOUNDRIES

# WHO BELIEVES IN US

Here is a list of just a few of our stisfied clients...

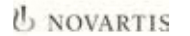



# HIGH PERFORMANCE VACUUMS SINCE 1972



19121 Marketplace Avenue, Building 1, Suite 165  
Plum Creek Business Park  
Kyle, Texas 78640

[www.depurecousa.com](http://www.depurecousa.com)  
[info@depurecousa.com](mailto:info@depurecousa.com)  
phone +1 737 70 44 347

