



M100  
JC  
LP  
H

**Depureco Industrial Vacuums USA**

19121 Marketplace Avenue, Building 1, Suite 165  
Plum Creek Business Park • Kyle • TX 78640

[www.depurecousa.com](http://www.depurecousa.com)  
[info@depurecousa.com](mailto:info@depurecousa.com)

3,3 HP  
**POWER**

5425 in<sup>2</sup>  
**FILTER**

Longopac  
**CAPACITY**



**3 POWERFUL BY-PASS MOTORS**

120V | 60 Hz  
Max Airflow= 336 CFM  
Max Depression= 98 inH2O



**STANDARD H 14 HEPA FILTER**

4340 in<sup>2</sup>



**TANGENTIAL INLET WITH SLIDING DAMPER**

Used in combination with the Jet Clean system

Conical polyester cartridge filter  
**M CLASS**



5425 in<sup>2</sup>



**JET CLEAN CLEANING SYSTEM**

Clean the filter with a powerful jet of air without stopping the unit.

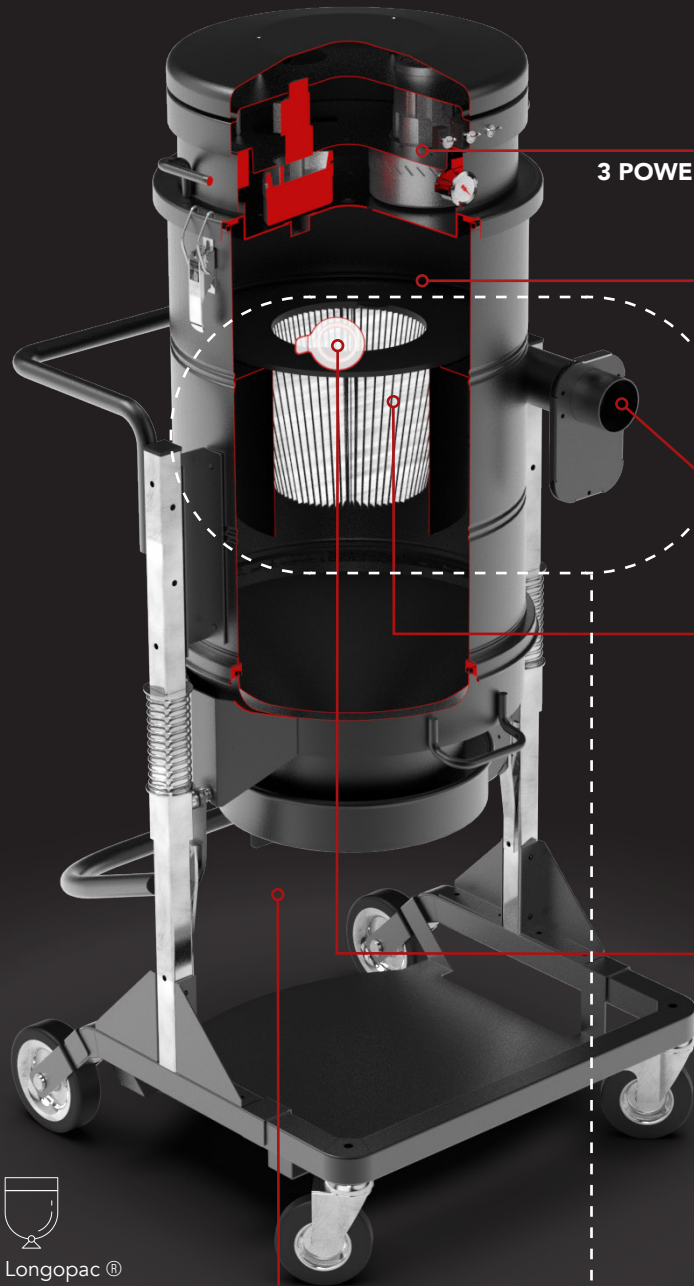

  
Longopac<sup>®</sup> bagging system

**HIGHLY TRANSPORTABLE**

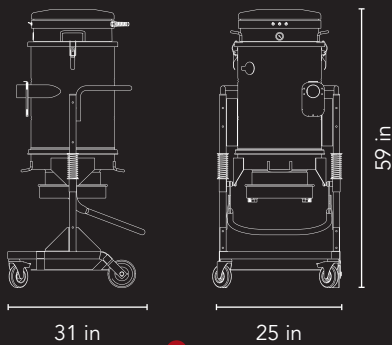

**Weight: 154 lbs**

**METAL SLEEVE FILTER PROTECTION**

The metal sleeve, surrounding the filter, protects it from the dust entering the vacuum chamber.

**EFFICIENT CYCLONIC EFFECT**

The dust, entering the vacuum, experiences a cyclonic effect that slows down the powder making it fall into the Longopac<sup>®</sup> bagging system.

**DEPURECO EXCLUSIVE CYCLONIC SYSTEM**

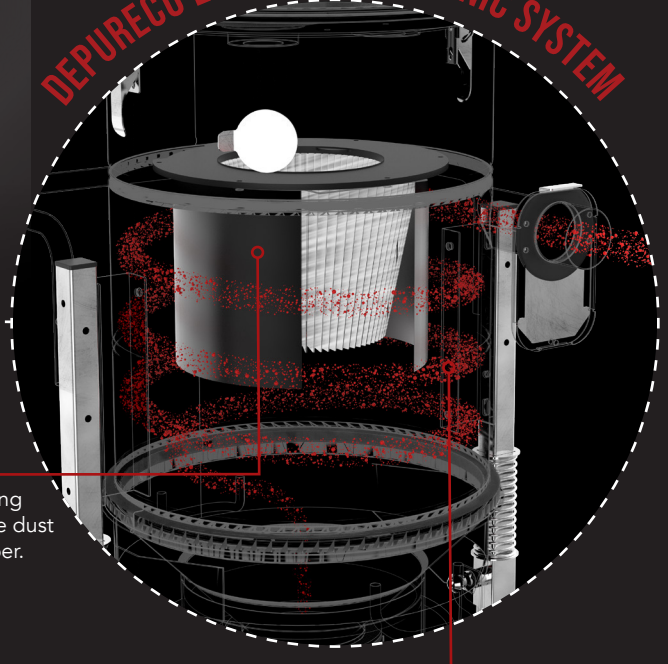

# SPEC SHEET

|  | Units                | M 100 JC LP H      |
|--|----------------------|--------------------|
| Motors   Type                                    |                      | 3 - By-Pass        |
| Power  | HP                   | 3,3                |
| Voltage   Frequency                              | V/Hz                 | 120/60             |
| Maximum vacuum                                   | inH2O                | 98                 |
| Maximum air flow                                 | CFM                  | 336                |
| Inlet  | Ø in                 | 2.75               |
| Noise level - (EN ISO 3744)                      | dB(A)                | 72                 |
| Bin capacity                                     | gal                  | Longopac®          |
| Dimensions                                       | in                   | 25.98 X 31.50      |
| Height   | in                   | 59.65              |
| Weight   | lb                   | 154                |
| <b>Primary filter</b>                            |                      |                    |
| Type   |                      | Star filter        |
| Surface area   Diameter<br>(Class EN 60335-2-69) | in <sup>2</sup>   in | 3720.01<br>M Class |
| Media  |                      | Polyester          |
| Filter cleaning                                  |                      | Manual shaker      |
| <b>Absolute filter</b>                           |                      |                    |
| Surface area                                     | in <sup>2</sup>      | 4,340              |
| <b>(Class - EN 1822)</b>                         |                      | H14                |
| Media  |                      | Fiberglass         |

## OPTIONAL



**AB**  
Accessory basket



**GRD**  
Grounding

## OPTIONAL FILTERS



**CONICAL POLYESTER**  
Hepa 13

## ACCESSORIES



**STEEL CONNECTOR**  
2.75 / 2 in



**Wet & Dry Kit**  
Ø 2 in



**Starter Kit**  
Ø 2 in