

M100



Depureco Industrial Vacuums USA

19121 Marketplace Avenue, Building 1, Suite 165
Plum Creek Business Park • Kyle • TX 78640

www.depurecousa.com
info@depurecousa.com

3,3 HP
POWER

3720.01 in²
FILTER

17/26 gal Bin
CAPACITY



3 POWERFUL BY-PASS MOTORS

120V
Max Airflow= 336 CFM
Max Depression= 98 inH2O



M CLASS
Stellar filter



MTF OPTIONAL
For difficult and sticky dust.



3720.01 in²

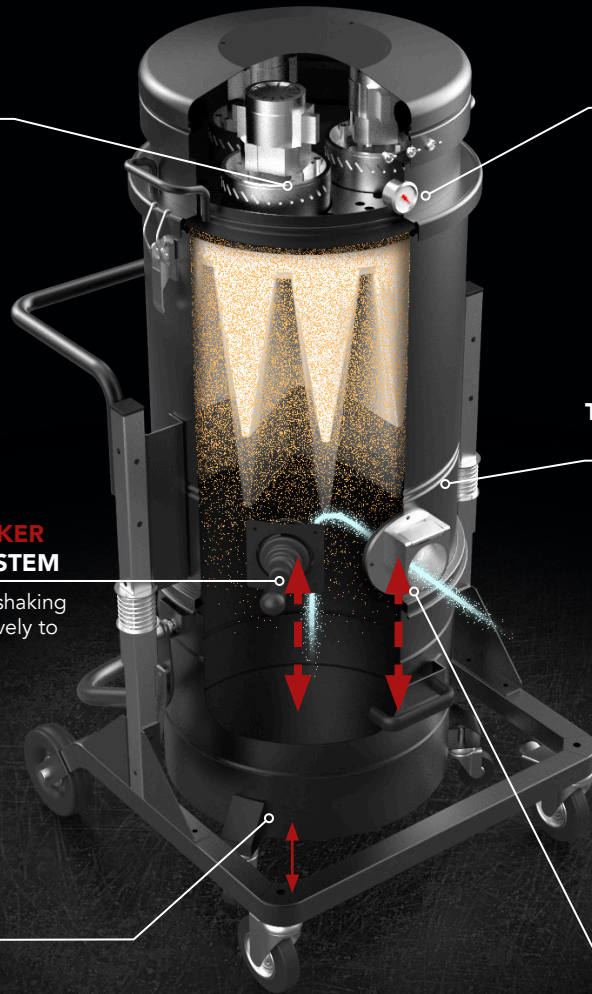

OPTIONAL TANGENTIAL INLET

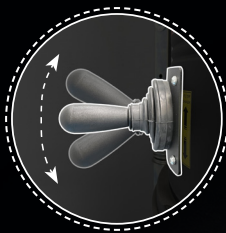

MANUAL SHAKER CLEANING SYSTEM

Smart handle for shaking the filter aggressively to release dust.



26 gal

DETACHABLE BIN ON WHEELS

INLET WITH DEFLECTOR

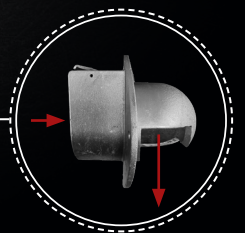

HIGHLY TRANSPORTABLE

WET & DRY FIXED BRUSH FLOOR TOOL

TILTABLE KIT FOR DUSTING BIN

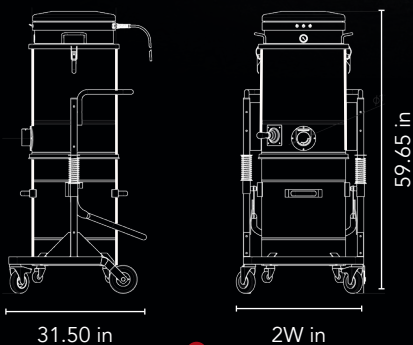

Weight: 176 lbs

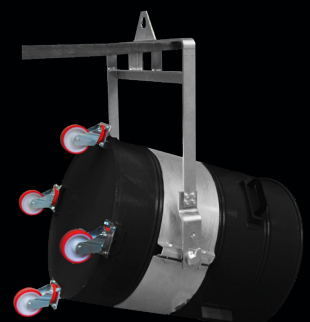

SPEC SHEET

	Units	M 100
Motors Type		3 - By-Pass
Power	HP	3.3
Voltage Frequency	V/Hz	120/60
Maximum vacuum	inH2O	98
Maximum air flow	CFM	336
Inlet	Ø in	2.75
Noise level - (EN ISO 3744)	dB(A)	72
Bin capacity	gal	26
Dimensions	in	25.98 X 31.50
Height	in	59.65
Weight	lb	176
Primary filter		
Type		Star filter
Surface area Diameter (Class EN 60335-2-69)	in ² in	3.800
Media		M Class
Filter cleaning		Polyester
		Manual Shaker
Absolute filter		
Surface area	in ²	4.400
(Class - EN 1822)		H14
Media		Fiberglass

OPTIONAL FILTERS



BFL
M class filter 409028,6 ft²

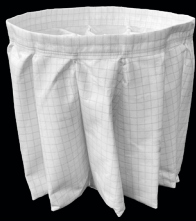

ANT M
Antistatic filter



MTF
Teflon filter



NOMEX
482° F Resistant filter



PTFE
PTFE filter 409028,6 ft²

OPTIONAL



AB
Accessory basket



GRD
Grounding



TAN
Tangential inlet + cyclone



BX
AISI 304 stainless steel bin



GX
AISI 304 BIN AND CHAMBER

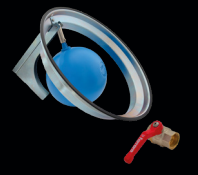

FLT
Floating device for liquids

ACCESSORIES



Iron reducer
Ø 2.75 / 2 in



Wet & Dry Kit
Ø 2 in



Starter Kit
Ø 2 in