



# RAM OIL 500 MP



**Depureco Industrial Vacuums USA**

19121 Marketplace Avenue, Building 1, Suite 165  
Plum Creek Business Park • Kyle • TX 78640

[www.depurecousa.com](http://www.depurecousa.com)  
[info@depurecousa.com](mailto:info@depurecousa.com)

-  Power: 3.3 HP
-  Liquid capacity: 132 gal  
Solid capacity: 11 gal
-  Sucking time: 74 gal/min  
Dumping time: 74 gal/min



## HIGHLY TRANSPORTABLE

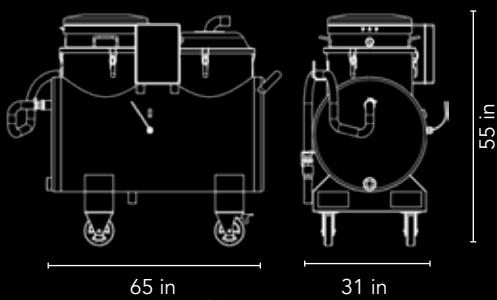

**Weight: 154 lbs**

## COMPACT AND EASY TO HANDLE

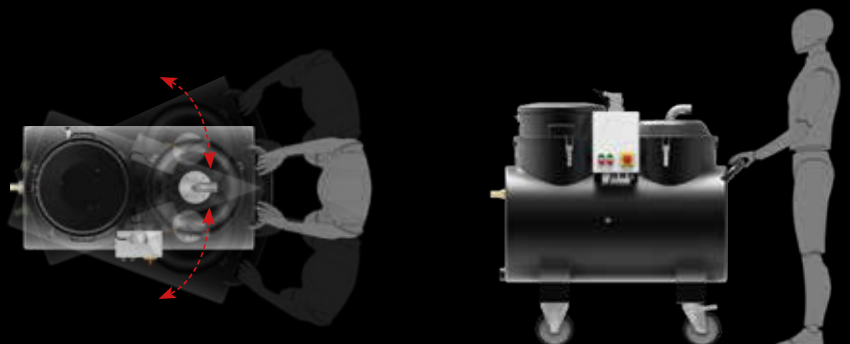

# SPEC SHEET

	Units	RAM OIL 500 MP
Motors   Type		3 - By-Pass
Power	HP	3.3
Voltage   Frequency	V/Hz	110/60
Maximum vacuum	inH2O	98
Maximum air flow	CFM	336
Inlet	Ø in	2
Noise level - (EN ISO 3744)	dB(A)	72
Liquid capacity	gal	132
Solid capacity	gal	11
Dimensions	in	31 x 65
Height	In	55
Weight	lb	485
Suction time	gal/min	74
Dumping time	gal/min	74
Discharge system		
Type		Immersion pump
Power	HP	1
Voltage/Frequency	V/Hz	110/60

## INCLUDED



**PPL disposal filter 150  
μ efficiency**



**TNT filter**



**Oil & swarf KIT**

## ACCESSORIES



**Oil & swarf KIT PRO**