

# M100



**Depureco Industrial Vacuums USA**

19121 Marketplace Avenue, Building 1, Suite 165  
Plum Creek Business Park • Kyle • TX 78640

[www.depurecousa.com](http://www.depurecousa.com)  
[info@depurecousa.com](mailto:info@depurecousa.com)

4 HP  
**POWER**

3720.01 in<sup>2</sup>  
**FILTER**

17/26 gal Bin  
**CAPACITY**



**3 POWERFUL BY-PASS MOTORS**

120V  
Max Airflow= 345 CFM  
Max Depression= 94 inH2O



**M CLASS**  
Stellar filter



**MTF OPTIONAL**  
For difficult and sticky dust.



3720.01 in<sup>2</sup>



**STANDARD H 14**  
**HEPA FILTER**



4340 in<sup>2</sup>

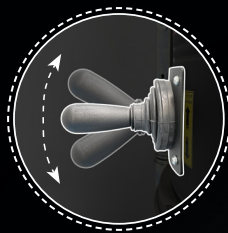
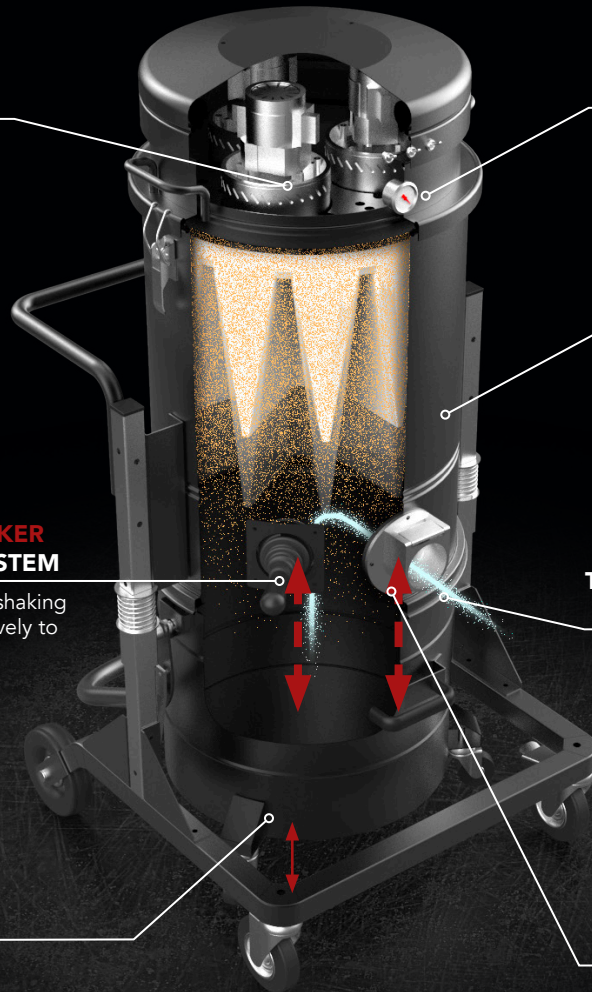

**MANUAL SHAKER**  
**CLEANING SYSTEM**

Smart handle for shaking the filter aggressively to release dust.

**OPTIONAL**  
**TANGENTIAL**  
**INLET**

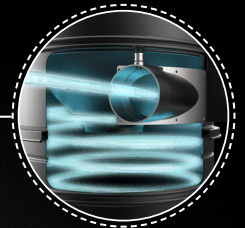

**INLET WITH**  
**DEFLECTOR**

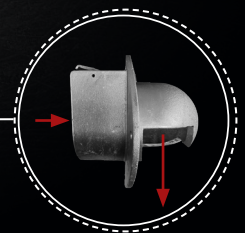

**26 gal**

**DETACHABLE BIN**  
**ON WHEELS**

**HIGHLY TRANSPORTABLE**

**WET & DRY FIXED BRUSH**  
**FLOOR TOOL**

**TILTABLE KIT FOR DUSTING**  
**BIN**



**Weight: 176 lbs**

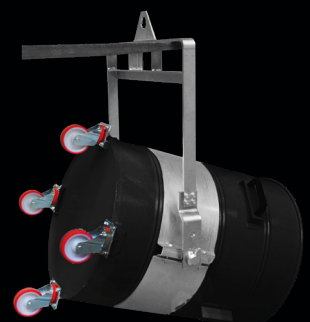

# SPEC SHEET

	Units	M 100 JC TAN LP
Motors   Type		3 - By-Pass
Power	HP	4
Voltage   Frequency	V/Hz	120/60
Maximum vacuum	inH2O	94
Maximum air flow	CFM	345
Inlet	Ø in	2.75
Noise level - (EN ISO 3744)	dB(A)	72
Bin capacity	gal	26
Dimensions	in	25.98 X 31.50
Height	in	59.65
Weight	lb	176
<b>Primary filter</b>		
Type		Star filter
Surface area   Diameter (Class EN 60335-2-69)	in <sup>2</sup>   in	3.800
Media		M Class
Filter cleaning		Polyester
		Manual Shaker
<b>Absolute filter</b>		
Surface area	in <sup>2</sup>	4.400
(Class - EN 1822)		H14
Media		Fiberglass

## OPTIONAL FILTERS



**BFL**  
M class filter 409028,6 ft<sup>2</sup>

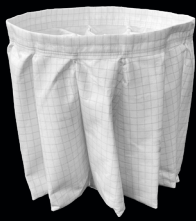

**ANT M**  
Antistatic filter



**MTF**  
Teflon filter



**NOMEX**  
482° F Resistant filter



**PTFE**  
PTFE filter 409028,6 ft<sup>2</sup>

## OPTIONAL



**AB**  
Accessory basket



**GRD**  
Grounding



**TAN**  
Tangential inlet + cyclone



**BX**  
AISI 304 stainless steel bin



**GX**  
AISI 304 BIN AND CHAMBER

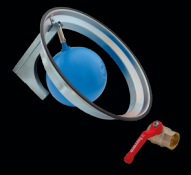

**FLT**  
Floating device for liquids

## ACCESSORIES



**Iron reducer**  
Ø 2.75 / 2 in



**Wet & Dry Kit**  
Ø 2 in

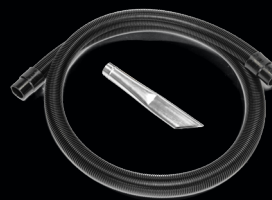

**Starter Kit**  
Ø 2 in